

Pneumatic Link Clamp -Retracting Model-

Model WFC



Larger Size Added: model WFC0320 (Cylinder Inner Diameter 32mm)

Lever Retracted to Avoid Interference during Workpiece Loading/Unloading

Compact Body and Compact Lever Movement

Features

- **Lever Retracted Lower than the Clamping Point**

Large lever retraction allows for wide angle of loading and unloading workpieces between operations.

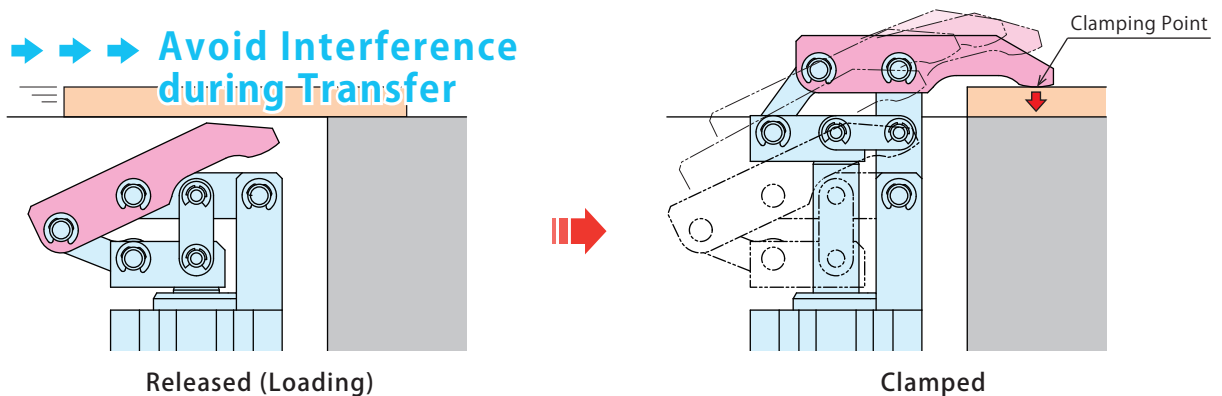

- **Enables to Clamp Difficult Clamping Points**

The compact lever-operating range enables to clamp difficult clamping points.

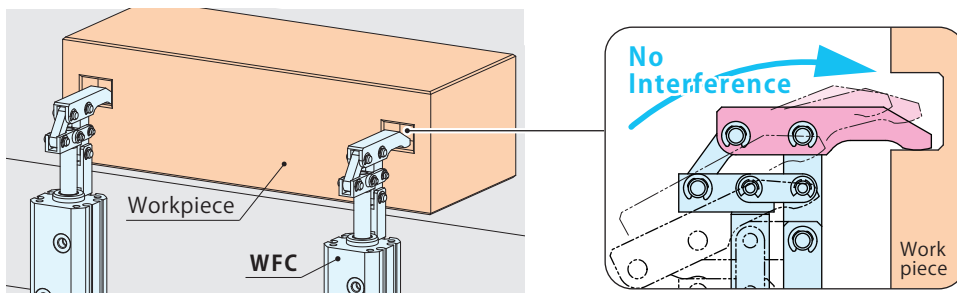

- **Excellent Coolant Resistance**

Our exclusive dust seal is designed to protect against high pressure coolant. It also has high durability against chlorine-based coolant by using a sealing material with excellent chemical resistance.

- **Standard Lever is also Available as an option**

Action Description

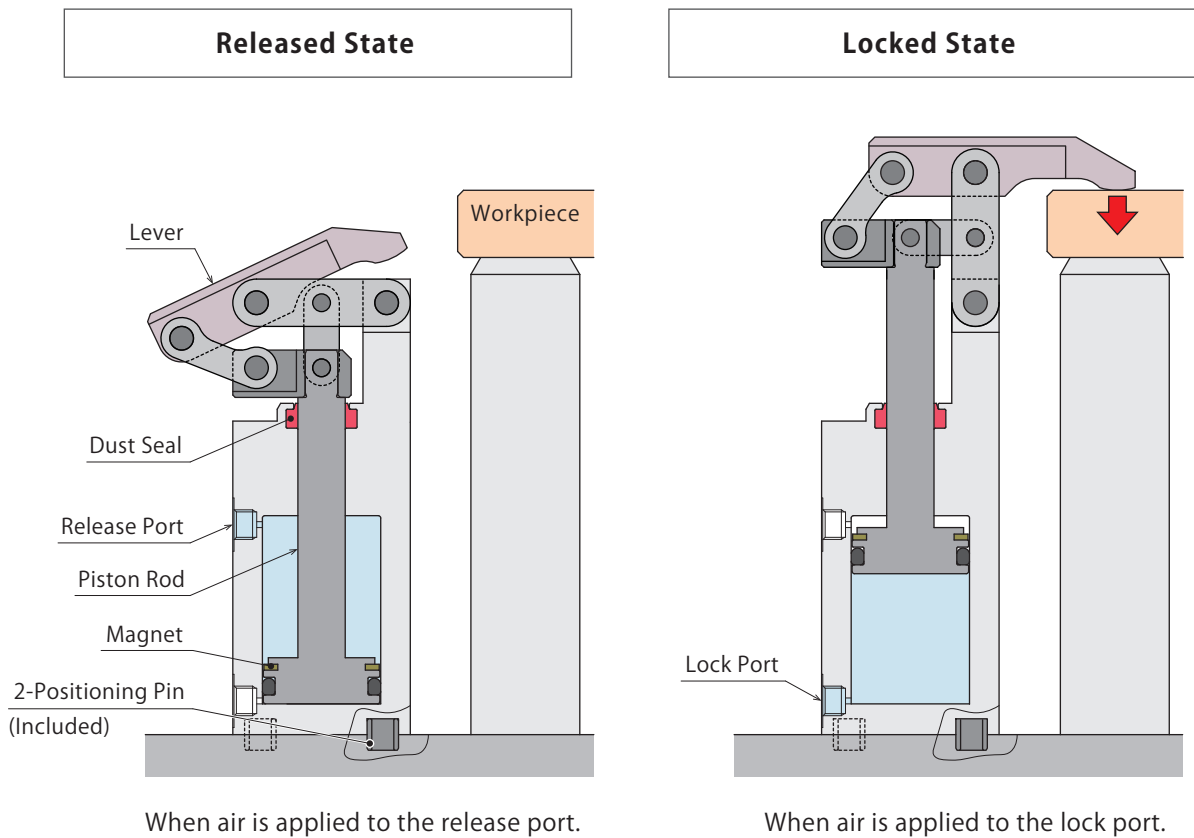

Application Example

For End of Arm Tooling

The largely retracted lever minimizes tooling clearance.

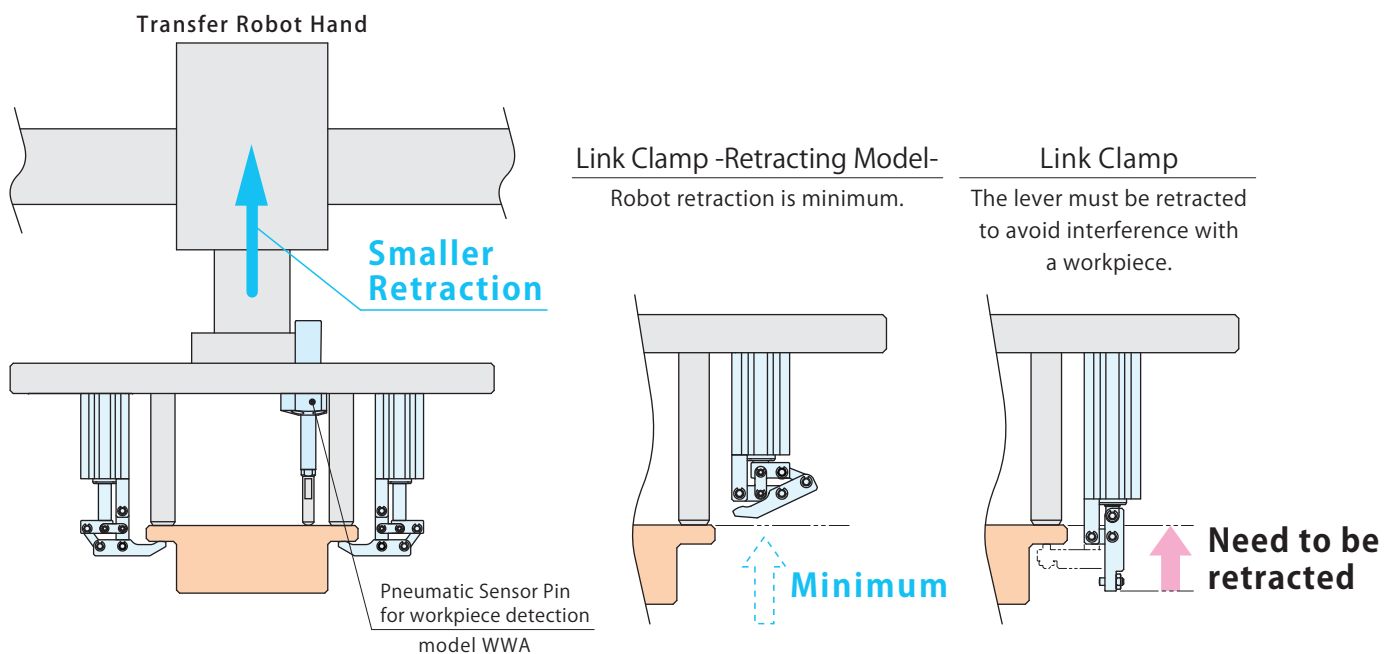

Auto Switch

Locking position and releasing position can be detected by an auto switch (prepared by customer).

Installation Sample 1



Installation Sample 2

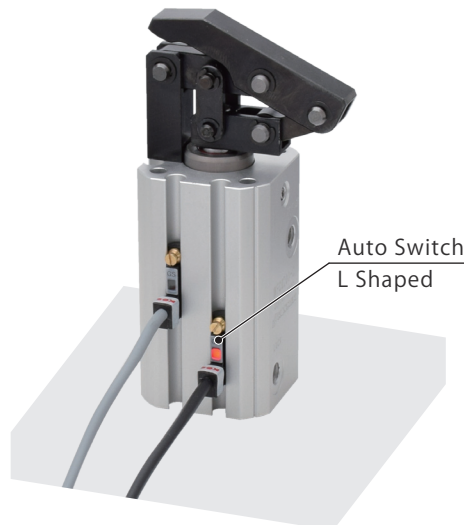

【Applicable Auto Switch / High-Accuracy Sensor for Air Cylinder】

Switch Type	Model No.	Output Method	Wiring Method	Cable Length	Shape	Protection Grade
Auto Switch ^{※3}	JEP0000-A2	Contact	2-Wire	1m	Straight	IP67
	JEP0000-A2L			3m		
	JEP0000-B2	Non-Contact : NPN Output	3-Wire	1m		
	JEP0000-B2L			3m		
	JEP0000-A2V	Contact	2-Wire	1m	L Shaped	
	JEP0000-A2VL			3m		
	JEP0000-B3B	Non-Contact	2-Wire	1m		
	JEP0000-B3BL			3m		
	JEP0000-B3C	Non-Contact : NPN Output	3-Wire	1m		
	JEP0000-B3CL			3m		
High-Accuracy Sensor for Air Cylinder ^{※1 ※3}	JES0000-02GN	Non-Contact : NPN Output N-Pole Sensor ^{※2}	3-Wire	1m	Straight	IP67
	JES0000-02GS	Non-Contact : NPN Output S-Pole Sensor ^{※2}				
	JES0000-02GPN	Non-Contact : PNP Output N-Pole Sensor ^{※2}				
	JES0000-02GPS	Non-Contact : PNP Output S-Pole Sensor ^{※2}				
	JES0000-02LGN	Non-Contact : NPN Output N-Pole Sensor ^{※2}			L Shaped	
	JES0000-02LGS	Non-Contact : NPN Output S-Pole Sensor ^{※2}				
	JES0000-02LGPN	Non-Contact : PNP Output N-Pole Sensor ^{※2}				
	JES0000-02LGPS	Non-Contact : PNP Output S-Pole Sensor ^{※2}				

Notes :

- For further information, refer to the product catalogs of Auto Switch (JEP) and High-Accuracy Sensor for Air Cylinder (JES) on our website. When using an auto switch not made by Kosmek, check specifications of each manufacturer.
 - Auto Switch / High-Accuracy Sensor for Air Cylinder may be stuck out of the Link Clamp -Retracting Model- depending on the installation position and direction.
- ※1. The detection range of High-Accuracy Sensor for Air Cylinder (JES) is different from that of Auto Switch (JEP), and even small stroke can be securely detected by JES. Refer to "Performance Curve" on the JES catalog for further information.
- ※2. When detecting both lock and release positions with High-Accuracy Sensor for Air Cylinder (JES), one each of N-pole sensor and S-pole sensor is required.
- ※3. JEP/JES series cannot be used in an environment which generates a magnetic field disturbance. Please use D-P3DWA (manufactured by SMC) for those environments.

Model No. Indication

WFC 020 0 - C A

1
 2
 3

1 Cylinder Inner Diameter

020 : Cylinder Inner Diameter = ϕ 20mm

032 : Cylinder Inner Diameter = ϕ 32mm

2 Design No.

0 : Revision Number

3 Lever Option

Blank : Lever not included

A : Standard Lever included

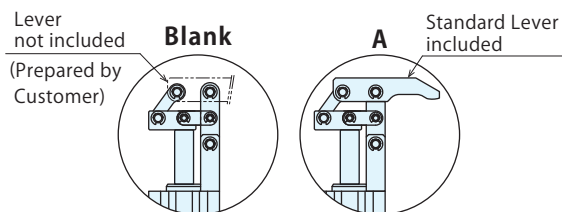

Specifications

Model No.			WFC0200-C□	WFC0320-C□
Cylinder Area for Locking	cm ²		3.14	8.04
Cylinder Inner Diameter ^{※1}	mm		20	32
Rod Diameter ^{※1}	mm		8	10
Clamping Force ^{※2} (Calculation Formula)	N		$F = \frac{3739 \times P}{L - 11}$	$F = \frac{11963 \times P}{L - 14}$
Full Stroke	mm		24	30
(Break down)	Lock Stroke	mm	22	28
	Extra Stroke	mm	2	2
Cylinder Capacity	Lock	cm ³	7.54	24.13
	Release	cm ³	6.33	21.77
Max. Operating Pressure	MPa		1.0	
Min. Operating Pressure ^{※3}	MPa		0.1	
Withstanding Pressure	MPa		1.5	
Operating Temperature	°C		0 ~ 70	
Usable Fluid			Dry Air	
Weight	3 In case of Blank	kg	0.14	0.35
	3 In case of A	kg	0.16	0.39

Notes :

※1. Clamping force cannot be calculated from the cylinder inner diameter and the rod diameter. Please refer to the clamping force curve on P.5.

※2. F : Clamping Force (N), P : Supply Air Pressure (MPa), L : Distance between the piston center and the clamping point (mm).

※3. Minimum pressure to operate the clamp without load.

Clamping Force Curve

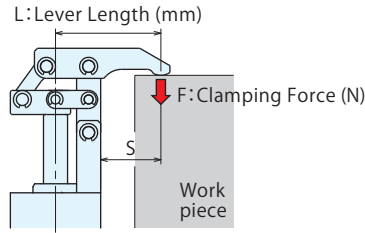

(How to Read the Clamping Force Curve)

In case of WFC0200:

When supply air pressure is 0.5MPa and lever length L is 35mm, clamping force becomes about 78N.

Notes :

※1. F : Clamping Force (N), P : Supply Air Pressure (MPa), L : Lever Length (mm). Cylinder force (When L=0) cannot be calculated from the calculation formula of clamping force.

1. The table and graph show the relationship between the clamping force (kN) and supply air pressure (MPa).
2. Values in the chart indicate clamping force when the lever locks a workpiece in horizontal position.
3. The clamping force varies depending on the lever length. Set the suitable supply air pressure based on the lever length.

WFC0200		Clamping Force ※1 Calculation Formula (N)				Min. Lever Length (L) (mm)
Air Pressure (MPa)	Cylinder Force (N)	Lever Length L (mm)				
		25	30	35 Std. Lever	50	
		$F = \frac{3739 \times P}{L-11}$				
1.0	314	267	197	156	96	25
0.9	283	240	177	140	86	25
0.8	251	214	157	125	77	25
0.7	220	187	138	109	67	25
0.6	188	160	118	93	58	25
0.5	157	134	98	78	48	25
0.4	126	107	79	62	38	25
0.3	94	80	59	47	29	25
0.2	62	53	39	31	19	25
0.1	31	27	20	16	10	25
Max. Op. Pressure (MPa)		1.0	1.0	1.0	1.0	

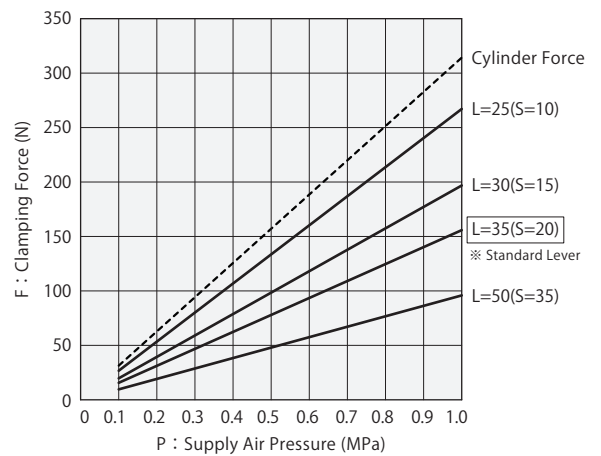

WFC0320		Clamping Force ※1 Calculation Formula (N)				Min. Lever Length (L) (mm)
Air Pressure (MPa)	Cylinder Force (N)	Lever Length L (mm)				
		31	40	46 Std. Lever	60	
		$F = \frac{11963 \times P}{L-14}$				
1.0	804	704	460	374	260	31
0.9	724	633	414	336	234	31
0.8	643	563	368	299	208	31
0.7	563	493	322	262	182	31
0.6	483	422	276	224	156	31
0.5	402	352	230	187	130	31
0.4	322	281	184	150	104	31
0.3	241	211	138	112	78	31
0.2	161	141	92	75	52	31
0.1	80	70	46	37	26	31
Max. Op. Pressure (MPa)		1.0	1.0	1.0	1.0	

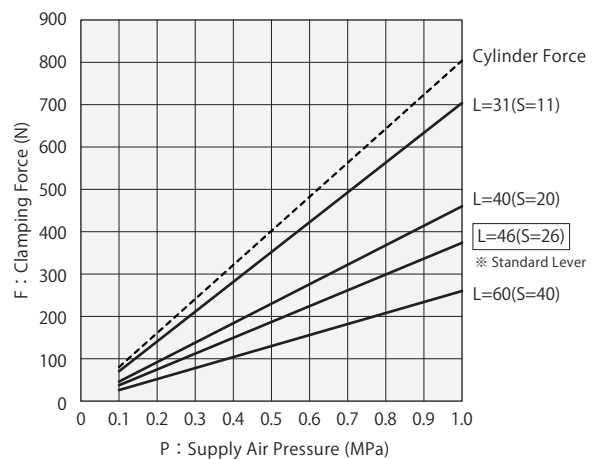

 **MEMO**

External Dimensions : WFC0200-C□

※ The drawing shows the locked state of WFC0200-CA.

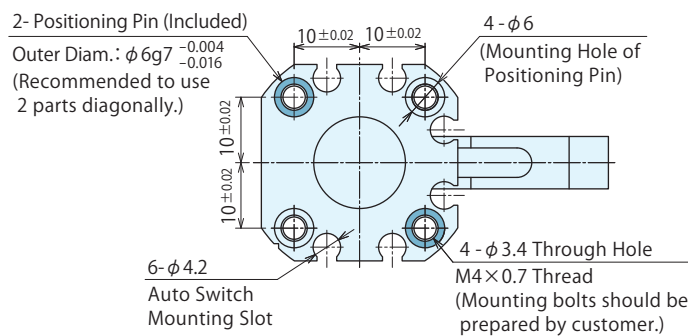
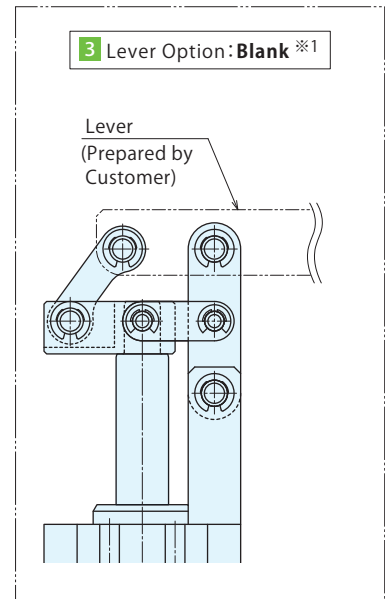
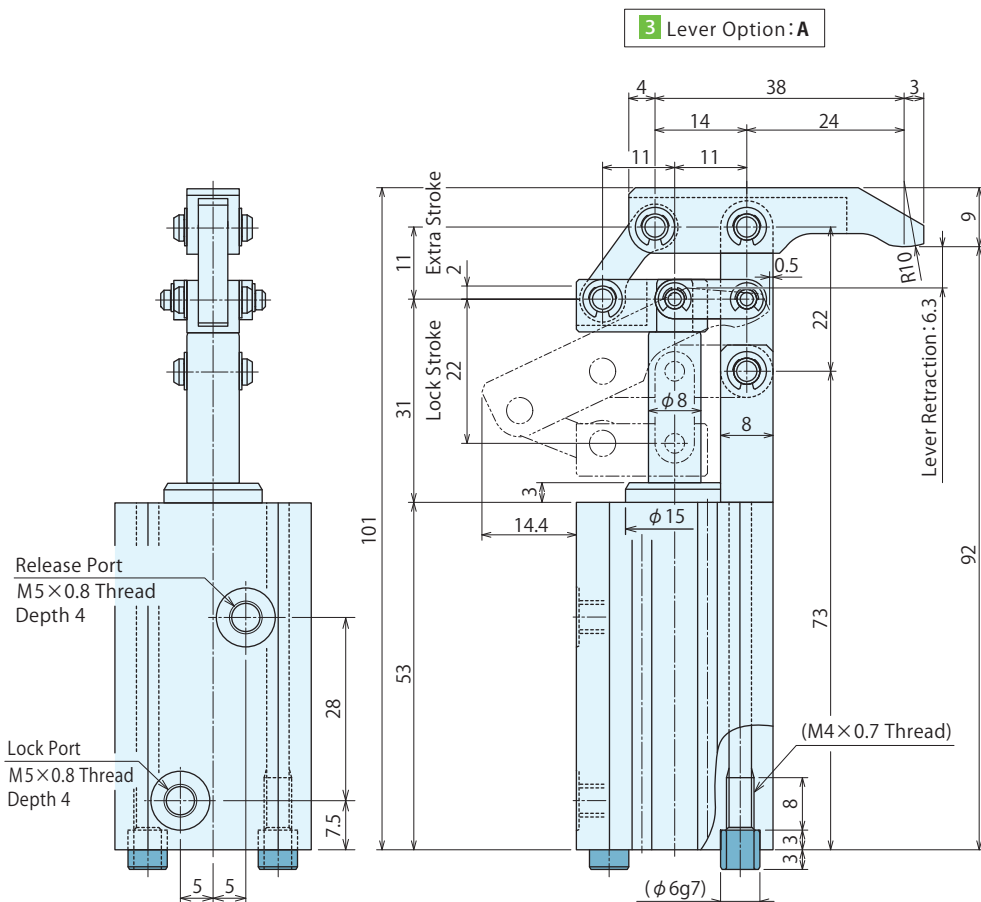
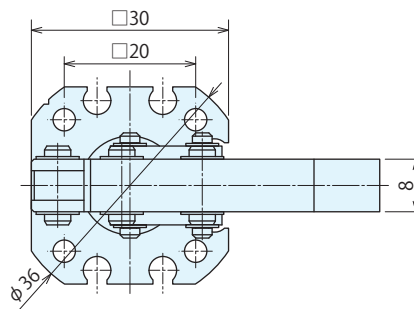

Notes :

- ※1. Please refer to **3** Lever Option : **A** for unlisted dimensions.
 1. Mounting bolts are not provided. Please prepare them according to the mounting position. (Refer to "Installation of Link Clamp -Retracting Model-" on P.12.)
 2. Please use the provided pin (equivalent to φ4f6, HRC60) as the lever mounting pin.

● Lever Design Dimensions for WFC0200

※ Reference for designing link lever for WFC0200.

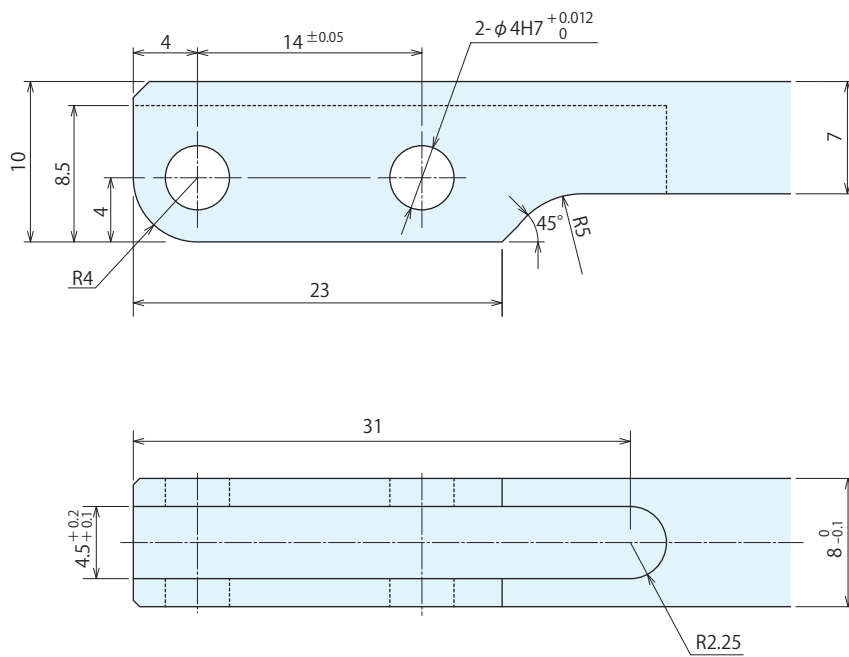

Notes :

1. Please design the link lever length according to the performance curve on P.5.
2. Use the attached pin (equivalent to $\phi 4f6$, HRC60) as the lever mounting pin.

External Dimensions : WFC0320-C□

※ The drawing shows the locked state of WFC0320-CA.

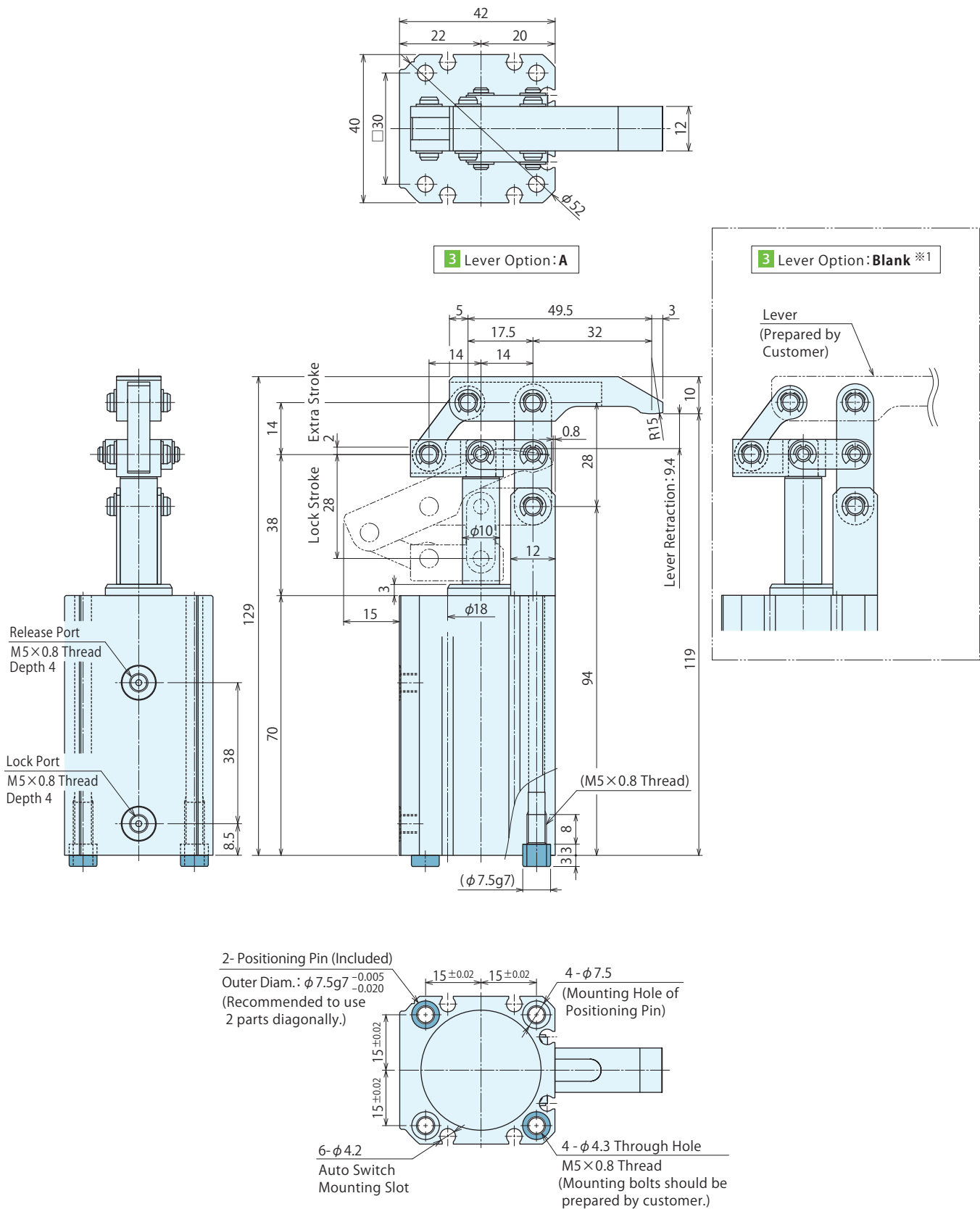

Notes :

- ※1. Please refer to **3** Lever Option: A for unlisted dimensions.
 1. Mounting bolts are not provided. Please prepare them according to the mounting position. (Refer to "Installation of Link Clamp -Retracting Model-" on P.12.)
 2. Please use the provided pin (equivalent to φ5f6, HRC60) as the lever mounting pin.

● Lever Design Dimensions for WFC0320

※ Reference for designing link lever for WFC0320.

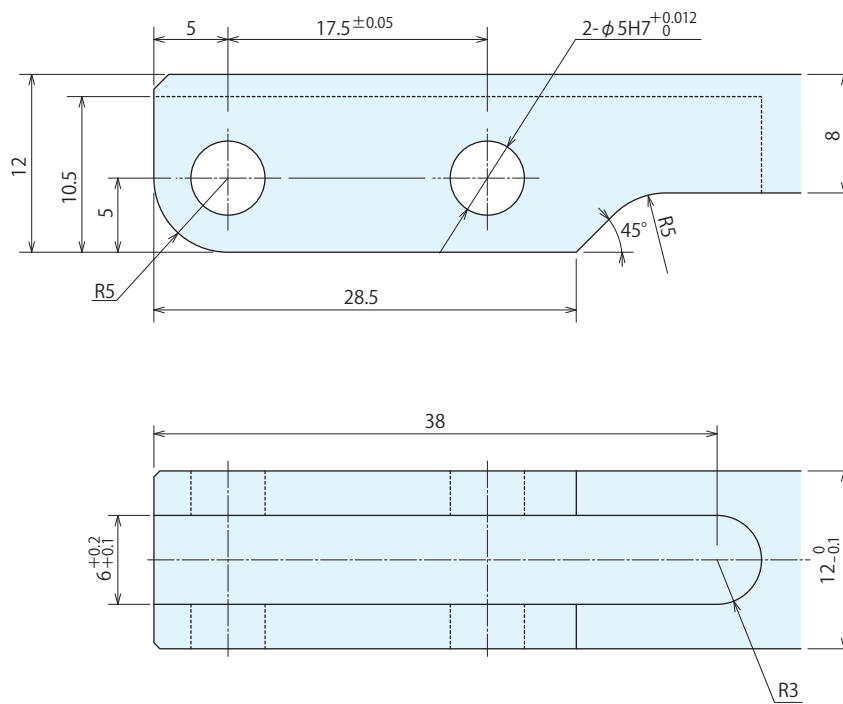

Notes :

1. Please design the link lever length according to the performance curve on P.5.
2. Use the attached pin (equivalent to $\phi 5f6$, HRC60) as the lever mounting pin.

Cautions

● Notes for Design

1) Check Specifications

- Please use each product according to the specifications.

2) Notes for Circuit Design

- Ensure there is no possibility of supplying air pressure to the lock port and the release port simultaneously. Improper circuit design may lead to malfunctions and damages.

3) Notes for Link Lever Design

- Clamping force varies depending on lever length. Applying excessive load will cause deformation, seizure, and air leakage. Please refer to the clamping force curve on P.5 and make sure to design the lever length appropriately.

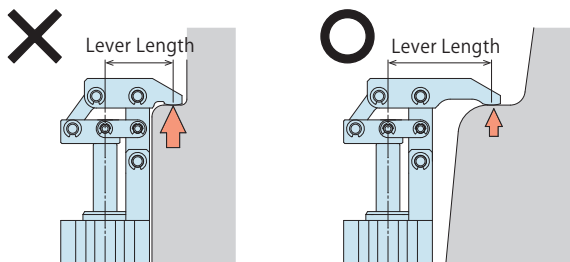

- Make sure no force is applied to the piston rod except from the axial direction.

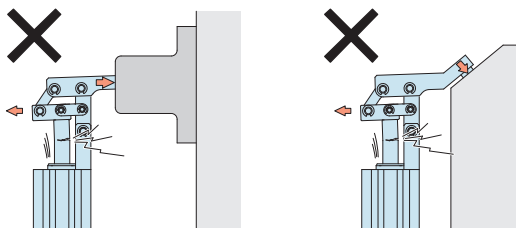

- Offset lever cannot be used. Offset load may damage the product.

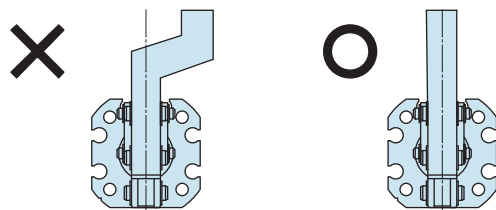

4) Protect the exposed area of the piston rod when using on a welding fixture.

- If spatter attaches to the sliding surface it could lead to malfunction and air leakage.

5) When clamping on a sloped surface of the workpiece

- Make sure the clamping surface and the mounting surface of the clamp are parallel.

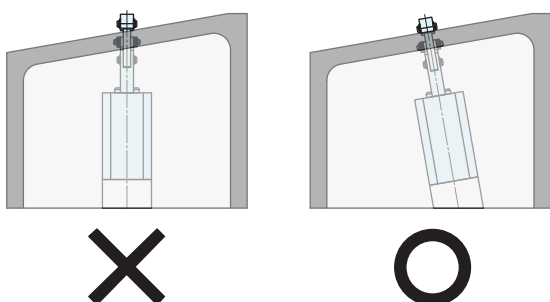

6) When using in a dry environment

- The link pin can be dried out. Grease it up on a regular basis.

7) Protective Cover Installation

- If the moving parts of the cylinder may endanger human life, please install the protective cover.

8) Speed Adjustment

- If the clamp operates too fast, the parts will be worn out and become damaged more quickly leading to equipment failure. Please adjust the locking time to be about 0.5 seconds.
- Install a speed control valve (meter-out) to the release port side and gradually control the flow rate from the low-speed side (small flow) to the designated speed. Controlling from the high-speed side (large flow) causes overload to the clamp leading to damage of a machine or device.

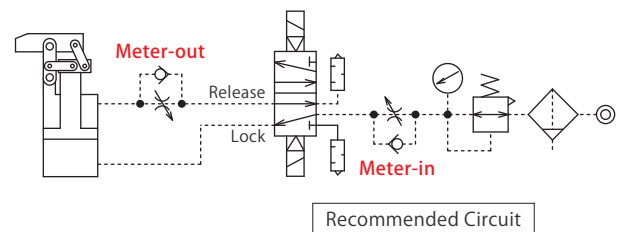

- When operating multiple clamps simultaneously, please set one speed controller (meter-out) to each clamp.

9) For Use of Auto Switch

- Select an auto switch depending on the environment.
- Please use D-P3DWA (SMC) for an environment which generates a magnetic field disturbance. Recommended Auto Switch Model : D-P3DWA (made by SMC)
- An auto switch may be stuck out of the clamp depending on the installation position and direction.
- Auto switch may be unstable when a ferromagnetic material (such as an iron plate) is near the cylinder.

● Installation Notes

1) Check the Usable Fluid

- Please supply filtered clean dry air.
- Oil supply with a lubricator etc. is unnecessary.
If oil is supplied with a lubricator, etc., the operation under low pressure and low speed may be unstable.
(When using lubricant, please supply lubricant continuously.)

2) Preparation for Piping

- The pipeline, piping connector and fixture circuits should be cleaned by thorough flushing. The dust and cutting chips in the circuit may lead to fluid leakage and malfunction.
- There is no filter provided with this product which prevents contamination in the air circuit.

3) Installation of the Product

- When installing the product, use 4 hexagonal socket bolts (with tensile strength of 12.9) and tighten them with the torque shown in the list below. Tightening with greater torque than recommended can damage the thread, dent the seating surface or break the bolt. When tapping, make sure the thread engaging length is longer than the minimum engaging length shown below. If the engaging length is too short, it may cause damage to the threads.

Installation Using the Through Holes

Model No.	Mounting Bolt Size	Tightening Torque (N·m)
WFC0200	M3×0.5	1.3
WFC0320	M4×0.7	3.2

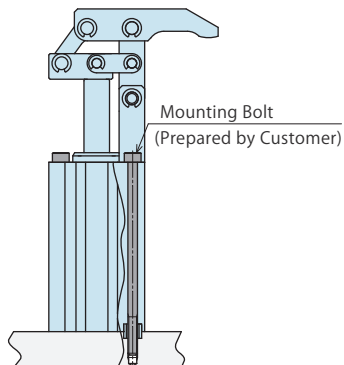

Installation Using Taps (Flange)

Model No.	Mounting Bolt Size	Min. Engaging Length (mm)	Tightening Torque (N·m)
WFC0200	M4×0.7	5	2.8
WFC0320	M5×0.8	6	4.8

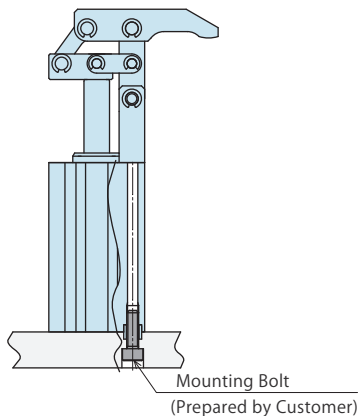

4) Installation / Removal of the Link Lever

- When inserting a link pin, do not hit the pin directly with a hammer.
When using a hammer to insert the pin, always use a cover plate with a smaller diameter than the spring ring groove on the pin.

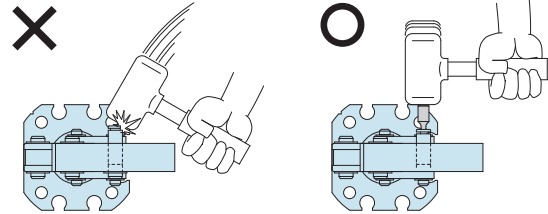

5) Speed Adjustment

- Adjust the speed so that the operating time is within 0.5 sec.
If the clamp operates too fast the parts will be worn out leading to premature damage and ultimately complete equipment failure.
- Turn the speed control valve gradually from the low-speed side (small flow) to the high-speed side (large flow) to adjust the speed.

6) Precautions for Trial Operation

- Avoid supplying large air flow right after the installation. The operating time will be very fast, and the clamp may be seriously damaged. Please install the speed controller (meter-in) near the air source and gradually supply air pressure.

7) Checking Looseness and Retightening

- At the beginning of the product installation, the bolt may be tightened lightly. Check the looseness and re-tighten as required.

8) Do not use deformed snap rings.

- When installing or replacing a lever, do not use open-mouthed or deformed snap rings for link pin. Snap rings may not be attached properly.



WAHLTEC GmbH
 T: +49 (7584) 9238883
 F: +49 (7584) 9238887
 kosmek@wahltec.de
 www.wahltec.de

Cautions

● Notes on Handling

- 1) It should be operated by qualified personnel.
 - Machines and devices with hydraulic and pneumatic products should be operated and maintained by qualified personnel.
- 2) Do not operate or remove the product unless the safety protocols are ensured.
 - ① Machines and devices can only be inspected or prepared when it is confirmed that the safety devices are in place.
 - ② Before the product is removed, make sure that the above-mentioned safety devices are in place. Shut off the pressure and power source, and make sure no pressure exists in the air and hydraulic circuits.
 - ③ After stopping the product, do not remove until the temperature drops.
 - ④ Make sure there is no trouble/issue in the bolts and respective parts before restarting a machine or device.
- 3) Do not touch a clamp while it is working. Otherwise, your hands may be injured.

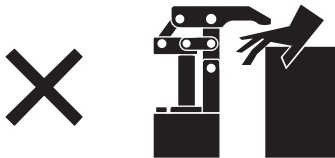

4) Do not disassemble or modify

- If the product is taken apart or modified, the warranty will be voided even within the warranty period.

● Maintenance and Inspection

- 1) Removal of the Product and Shut-off of Pressure Source
 - Before the product is removed, make sure that safety devices and preventive devices are in place. Shut off the pressure and power source, and make sure no pressure exists in the air and hydraulic circuits.
 - Make sure there is no trouble/issue in the bolts and respective parts before restarting.
- 2) Regularly clean the area around the piston rod and link pin.
 - If it is used when the surface is contaminated with dirt, it may lead to packing seal damage, malfunctioning and fluid leakage.

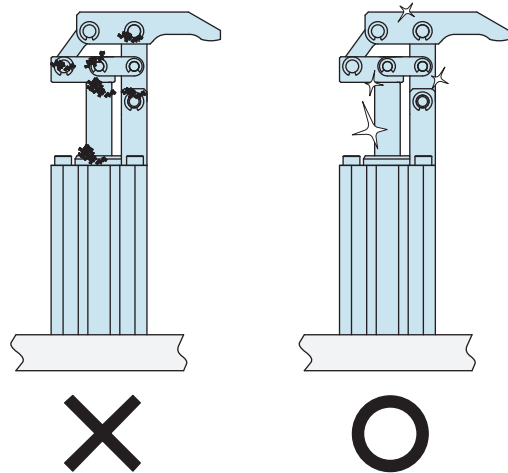

- 3) Regularly tighten pipe, mounting bolt, snap ring and others to ensure proper use.
- 4) Make sure there is a smooth action without an irregular noise.
 - Especially when it is restarted after left unused for a long period, make sure it can be operated correctly.
- 5) The product should be stored in the cool and dark place without direct sunshine or moisture.
- 6) Please contact us for overhaul and repair.

● Warranty

1) Warranty Period

- The product warranty period is 18 months from shipment from our factory or 12 months from initial use, whichever is earlier.

2) Warranty Scope

- If the product is damaged or malfunctions during the warranty period due to faulty design, materials or workmanship, we will replace or repair the defective part at our expense. Defects or failures caused by the following are not covered.
 - ① If the stipulated maintenance and inspection are not carried out.
 - ② Failure caused by the use of the non-confirming state at the user's discretion.
 - ③ If it is used or operated in an inappropriate way by the operator. (Including damage caused by the misconduct of the third party.)
 - ④ If the defect is caused by reasons other than our responsibility.
 - ⑤ If repair or modifications are carried out by anyone other than Kosmek, or without our approval and confirmation, it will void warranty.
 - ⑥ Other caused by natural disasters or calamities not attributable to our company.
 - ⑦ Parts or replacement expenses due to parts consumption and deterioration. (Such as rubber, plastic, seal material and some electric components.)

Damages excluding from direct result of a product defect shall be excluded from the warranty



WAHLTEC GmbH
T: +49 (7584) 9238883
F: +49 (7584) 9238887
kosmek@wahltec.de
www.wahltec.de